

Zhaga casDMX

USA & Canada

DMX Engineering LLC

<http://dmx.engineering>



Casambi 12-Channel DMX Master with Casambi CBM003 Long Range Radio

Product Description

Zhaga casDMX is a Bluetooth controllable, Casambi enabled, 12 channel DMX-512 master dimmer that generates a single DMX Universe. The casDMX connects DMX enabled lighting devices and fixtures to a Casambi network to gain full color control. The Zhaga casDMX is connected between a 12-24 VDC Class 2 power supply and provides a non-isolated DMX-512 universe.

Zhaga casDMX can control luminaires using Casambi color widgets, and up to 12 DMX channels utilizing Casambi sliders in Evolution mode. The Zhaga casDMX is an ideal DMX controller for RGBW and tunable white (TW) applications since a user choice of multiple Casambi Profiles allow for selection of four, eight and 12 slider channels and standard Casambi 4-channel color controls.

Zhaga casDMX can be controlled with Casambi app which can be downloaded free of charge from the Apple App Store and Google Play Store.

Different Casambi enabled products can be used from a simple one luminaire direct control to a complete and full featured light control system where up to 250 units form automatically an intelligent Casambi mesh network.

Zhaga 40mm Z10 Mechanical Diagram

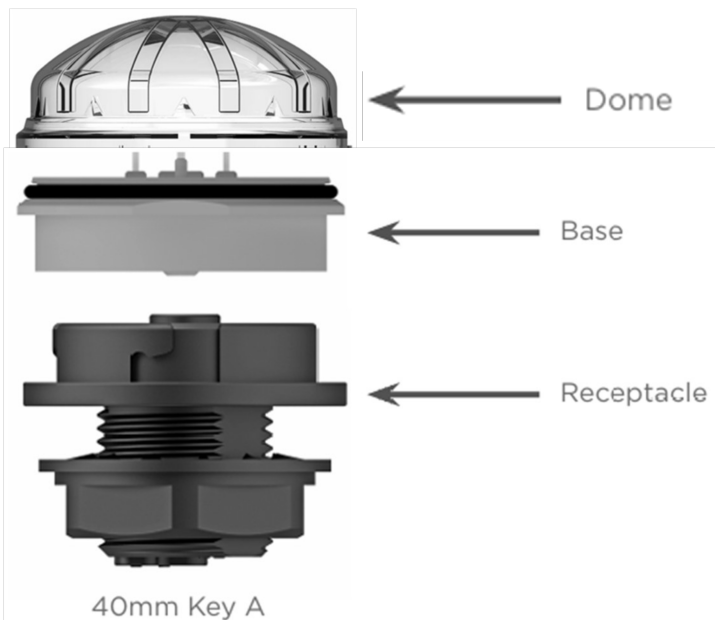

Dimensions

48mm Round, 30mm tall

Weight: 2.2 oz

DMX Engineering LLC

9221 E. Baseline Road, Suite 109-492

Mesa, AZ 85209

Certifications

Contains FCC ID: 2ALA3-CBM003B

Contains IC: 22496-CBM003B

Conforms to UL STD 916

Certified to CSA STD C22.2#205



Compatible Mobile Devices



iPhone 4S or later
iPad 3 or later
iPod Touch 5th gen or later



Android 4.4 or later devices
produced after 2013 with full

Technical Data

Input

Voltage range: +8-24 VDC, Class 2

No-load input current: 30 mA

DMX-512 Output

3-wire non-isolated DMX-512

Radio transceiver

Casambi CBM003B Radio Module

Operating frequencies: 2.401-2.483 Ghz

Maximum output power: typ. +8 dBm

-103 dBm RX sensitivity in long-range mode

Operating conditions

IP66 (non submersible)

Ambient temperature, ta: -13...+113°F (-25...+45°C)

Max. case temperature, tc: +167°F (+75°C)

Storage temperature: -13...+167°F (-25...+75°C)

Max. relative humidity: 0...80%, non-cond.

Recommended Interface Connector

TE LUMAWISE Endurance S

40 mm Z10-enabled keyed connector system

Mating connectors:

2343403-1, 2363638-2 or 1-2363638-2

TE Z10 Connector Signals

Pin 1 = 12=24VDC

Pin 2 = Ground (share with DMX ground as well)

Pin 3 = DMX+

Pin 4 = DMX-

Installation

Connect a Class 2 power supply with +12-24 VDC output (constant voltage) to the input connector of Zhaga casDMX. Be sure not to use a constant current LED driver and make sure that the wire connection polarity is correct before powering the unit on.

The product has one DMX universe, out with a DMX+ and DMX– connection, making sure to share the DMX Ground connection with the DC power ground signal. Connect the DMX load wires accordingly.

The Zhaga casDMX can be configured having different types of outputs, such as four channel RGBW (color picker), four, eight or 12 individual slider channels. DMX addresses start at channel or address 1, and are sequential. These configurations can be made by the end user from Casambi App using Profiles. As default, the Zhaga casDMX is delivered with the RGBW configuration. Vendor Parameters allow for changing the DMX Start Address, and options for DMX signal output, and support for repeating channels in use cases like linear lights.

The Zhaga casDMX is intended to be located in free air, and should not be placed in a metal enclosure, such as inside metal junction boxes. Metal will attenuate radio signals which are crucial to the operation of the product. If the product will have to be installed into a junction box, make sure to use a plastic junction box. TE has multiple sockets that are compatible with the Zhaga casDMX and can be found on their website at <https://www.te.com/en/plp/street-lighting-connectors/Y44Eb.html>.

The Zhaga casDMX is an ETL Listed Open-Type device which means that it will have to be used together with a Class 2 power supply with maximum output power of 100 VA. The product can be installed outside of junction box. Make sure to comply with National Electric Code in installation and when selecting installation wires.

Range

The range between two Zhaga casDMX's or between a Zhaga casDMX and a mobile device can vary depending on obstacles and surrounding material. The open air range between two Zhaga casDMXs can be in excess of 1000 meters, but if the unit is encapsulated into a metal structure, the range can be only few feet. The mobile device can be the range limiter when connecting it to the Zhaga casDMX. Thorough testing is highly suggested.

Casambi uses mesh network technology so each Zhaga casDMX acts also as a repeater. When testing the network, it is important to test that each unit can be controlled from any point of the network covered area.

Compliance Statement

This device complies with part 15 of the FCC Rules. Operation is subject to the following two conditions:

- (1) This device may not cause harmful interference, and
- (2) This device must accept any interference received, including interference that may cause undesired operation.

Warning

Changes or modifications not expressly approved by DMX Engineering and Design LLC could void the user's authority to operate the equipment.

FCC Interference Statement

This equipment has been tested and found to comply with the limits for a Class B digital device, pursuant to Part 15 of the FCC Rules. These limits are designed to provide reasonable protection against harmful interference in a residential installation. This equipment generates, uses and can radiate radio frequency energy and, if not installed and used in accordance with the instructions, may cause harmful interference to radio communications. However, there is no guarantee that interference will not occur in a particular installation. If this equipment does cause harmful interference to radio or television reception, which can be determined by turning the equipment off and on, the user is encouraged to try to correct the interference by one of the following measures:

- Reorient or relocate the receiving antenna.
- Increase the separation between the equipment and receiver.
- Connect the equipment into an outlet on a circuit different from that to which the receiver is connected.
- Consult the dealer or an experienced radio/TV technician for help.

Radiation Exposure Statement for Canada

This device complies with Industry Canada's licence-exempt RSSs. Operation is subject to the following two conditions:

- (1) This device may not cause interference
- (2) This device must accept any interference, including interference that may cause undesired operation of the device.

This equipment is exempt from the routine RF exposure evaluation requirements of RSS-102. This equipment should be installed and operated with a minimum distance of 20 cm between the antenna and the user or bystanders.

Le présent appareil est conforme aux CNR d'Industrie Canada applicables aux appareils radio exempts de licence. L'exploitation est autorisée aux deux conditions suivantes:

